

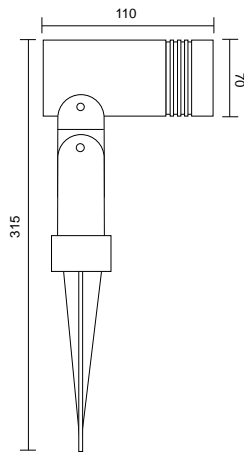

energy 6



dimension (mm)

Honey comb Louvers

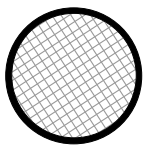

ADVANTAGES

- Architectural stylish and appearance
- Fully aluminium
- Easy maintenance
- Anti corrosion
- Choice of colour

APPLICATION

- Architectural building and landscape
- Tree lighting, walkway, square, park

FEATURES

- Die cast aluminium housing and frame (optional – earth spike).
- Finished with epoxy powder coating, resistant to corrosion.
- Standard colour – Black.
- Thermal Shock resistant tempered glass in a die cast aluminium frame.
- Weatherproof and durable silicon sealed rubber gasket.
- Provides narrow and wide beam photometric distribution.
- Ceramic lamp holder and silver plate contact.
- Plinth mounting standard, spike mounting available upon request.
- Honey comb Louvers available upon request.

CHARACTERISTICS

- Optical assembly : IP 66
- Electrical Insulation : Class 1
- Voltage : 220V/240V
- Wattage : 50W MAX
- Lamp Type : MR16
- Dimensions (mm) : $\varnothing 70(L) \times 110(W) \times 315(H)$
- Approx. Net weight : 1.5~2 kg

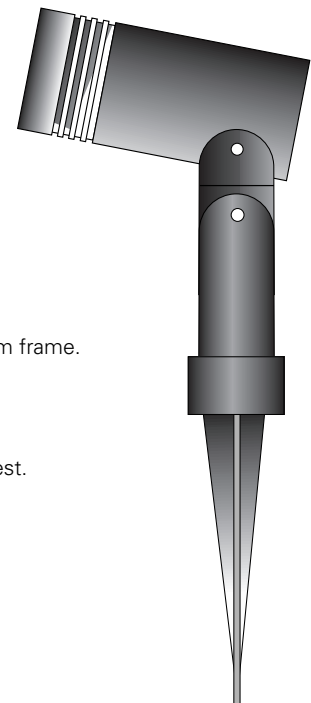

Model No.	Description	Voltage	Frequency	Lamp
GPKP0041	ENERGY 6 50W MAX MR16	220-240V	50-60Hz	GU10
GPKP0041	ENERGY 6 12V 50W MR16 C/W Remote Gear & Lamp	220-240V	50-60Hz	GU10

ordering information