

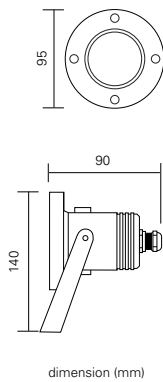

aquaris 6



ADVANTAGES

- High performance, easy maintenance
- Stainless steel, anti corrosion

APPLICATION

- Pools, fountains

FEATURES

- Underwater grade stainless steel housing and cover.
- Stainless steel screws.
- Clear tempered glass.
- Weather proof silicone gasket.
- Pg9 brass nickel plated cable gland.
- Come with 6 meters h07rn-f underwater cable.
- External transformer (not include).

CHARACTERISTICS

- Optical assembly : IP 68 (1.5 meters)
- Electrical Insulation : Class III
- Voltage : 220V~240V
- Wattage : 50W
- Dimensions (mm) : 95(L) x 90(W) x 140(H)

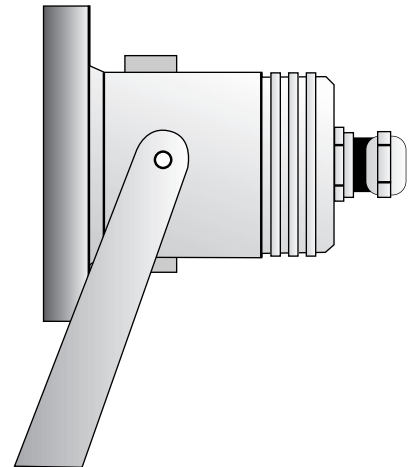

Model No.	Description	Voltage	Frequency	Lamp
GPCP0671	AQUARIS 6 50W C/W Gear & Lamp	220-240V	50-60Hz	Gu5-3

ordering information