

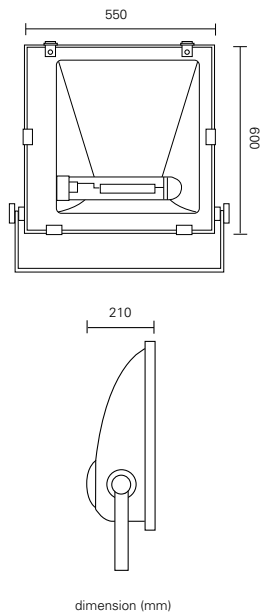

regal 1000



**ADVANTAGES**

- High performance & easy maintenance
- Full aluminium die-cast body
- Heat resistant, tempered glass
- Low wind surface

**APPLICATION**

- Sport Field, indoor arena, large area
- Monumental, building, recreation, airport apron

**FEATURES**

- Die cast aluminium housing with cooling fins.
- Epoxy powder paint finish.
- Standard colour – Black or White.
- Resistant to corrosive environment.
- High reflectance; anodised and polished aluminium reflector.
- Tempered flat glass, resistant to thermal shock and impact. Installed on the body with stainless steel external clips weather proof and durable silicon rubber sealing gaskets.
- Asymmetrical beam.
- Ceramic lamp holder and silver plated contact – Standard E40.
- Hot instant restart system available upon request.

**CHARACTERISTICS**

- Optical assembly : IP 65
- Ballast Compartment : IP 65
- Electrical Insulation : Class 1
- Voltage : 220V~240V 50/60 Hz
- Wattage : 1000W
- Lamp type : HPS or M/H
- Dimensions (mm) : 550(L) x 210(W) x 600(H)
- Approx. net weight : 12~14 kg (w/o control gear)

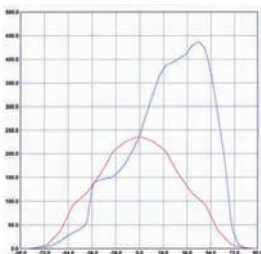
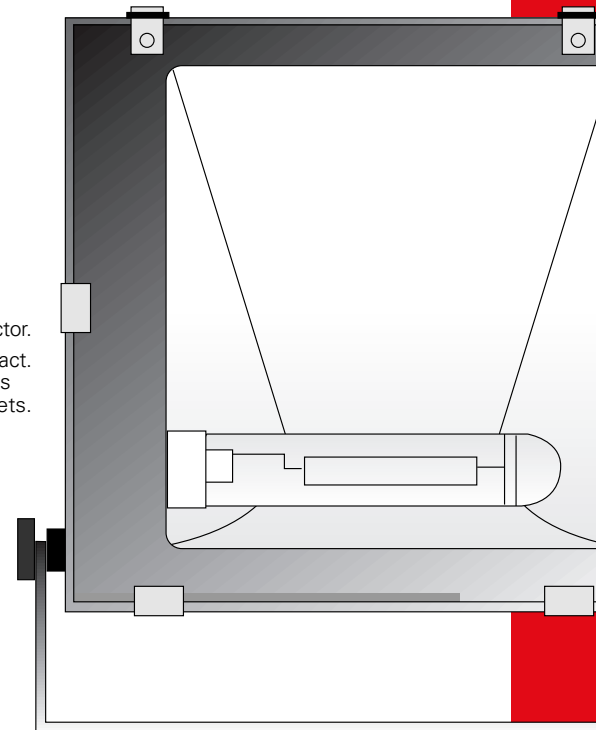

Regal 1000 1000W MHL

Model No.	Description	Voltage	Frequency	Lamp
GPCP0317	REGAL 1000W HPS C/W Control Gear & Lamp	220V-240V	50-60Hz	E40
GPCP0318	REGAL 1000W M/H C/W Control Gear & Lamp	220V-240V	50-60Hz	E40

ordering information