

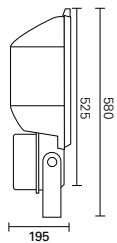

jet 1000

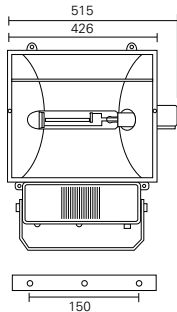

dimension (mm)

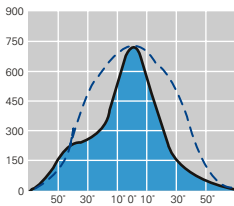

Jet 1000 Symmetrical peened
MT (JM-T) 1000W E40

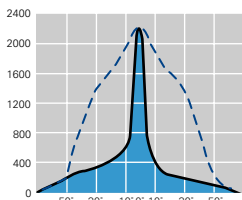

Jet 1000 Symmetrical narrow
ST (SAP-T) 1000W E40

ADVANTAGES

- High performance & easy maintenance
- Fully aluminium and glass
- Low wind surface = 0.203m²

APPLICATION

- Sport Field, indoor area, airport apron
- Monumental, building, large area
- Recreation, stadium with broadcasting

FEATURES

- Die cast aluminium housing with cooling fins.
- Finished with epoxy powder paint – Black colour.
- Resistant to corrosive environment.
- High reflectance, anodised and polished reflector attach in housing.
- Tempered flat glass, resistant to thermal, shock and impact. Installed on the body with stainless steel external screws and weather proof silicon rubber sealing gaskets.
- Internal louvre provides better control of the luminous flux and glare reduction.
- Provide narrow and wide beam photometric distribution.
- Ceramic lamp holder and silver plated contact.
- Hot instant restart system available upon request.
- Anti-vibration kit available upon request.

CHARACTERISTICS

- Optical assembly : IP 66
- Ballast Compartment : IP 66
- Electrical Insulation : Class 1
- Voltage : 220V~240V 50/60 Hz
- Wattage : 600~1000W
- Lamp type : HPS or M/H
- Lamp holder type : E40
- Dimensions (mm) : 515(L) x 195(W) x 580(H)
- Approx. Net weight : 9.7~20.6 kg

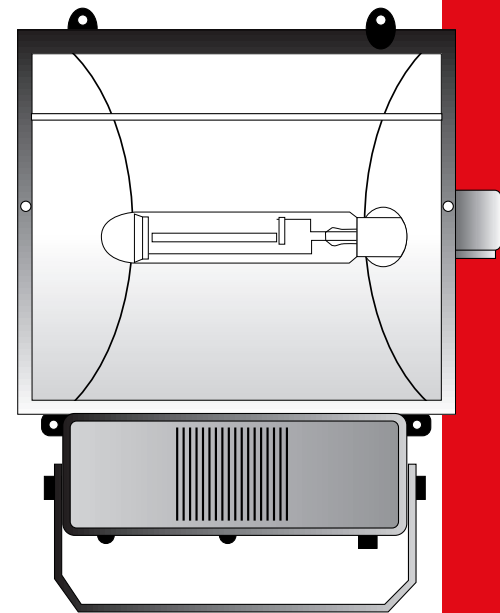

Model No.	Description	Voltage	Frequency	Lamp
FACP0021	JET 1000 1000W MH C/W Gear & Tube	220V-240V	50-60Hz	E40
FACP0022	JET 1000 1000W HPS C/W Gear & Tube	220V-240V	50-60Hz	E40

ordering information