

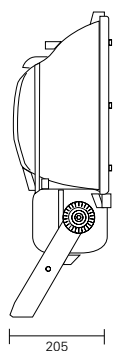

lightmaster 1000

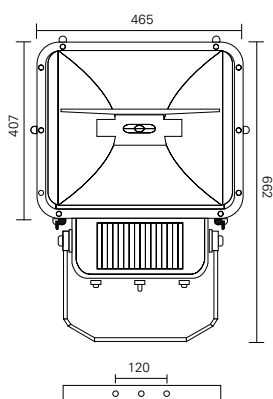

dimension (mm)

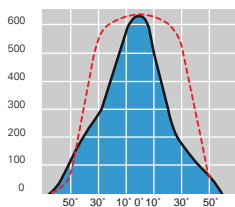

MD 1000W short arc



Grille, Zinc plated and steel coated in black colour.



Safety steel grille to be used with special glass.



Steel anti-glare louvre. Zinc plated and steel coated in black colour.

ADVANTAGES

- Compact, high efficiency & easy maintenance
- Die-cast aluminium

APPLICATION

- Sport fields, indoor areas, large areas, airport aprons
- Monumental buildings, recreations, stadiums
- Suitable for installation on masts and line arrangements up to 40M high above ground

FEATURES

- Die cast aluminium housing with cooling fins.
- Impact test is 7 Joules.
- Finished with epoxy powder upon phosphochromate treatment. Standard colour – Grey.
- Resistant to corrosive environment.
- High reflectance, anodised and polished reflector attach in housing.
- Tempered flat glass, resistant to thermal, shock and impact. It permanently sealed and gasketed in a cast frame.
- Built-in ignitor. Rear re-lamping door with hand-turn, without altering position corrosion resistant fasteners.
- Provide narrow, medium and wide beam photometric distribution.
- Optional accessories for internal glare/spill light control arc cut off skirt.
- Hot instant restrike system available upon request.

CHARACTERISTICS

- Optical assembly : IP 66
- Ballast Compartment : IP 66
- Electrical Insulation : Class I or Class II
- Voltage : 220V~240V 50/60Hz
- Wattage : 1000W
- Lamp type : M/H (double ended lamp)
- Dimensions (mm) : 465(L) x 205(W) x 662(H)
- Approx. Net weight : 14 kg

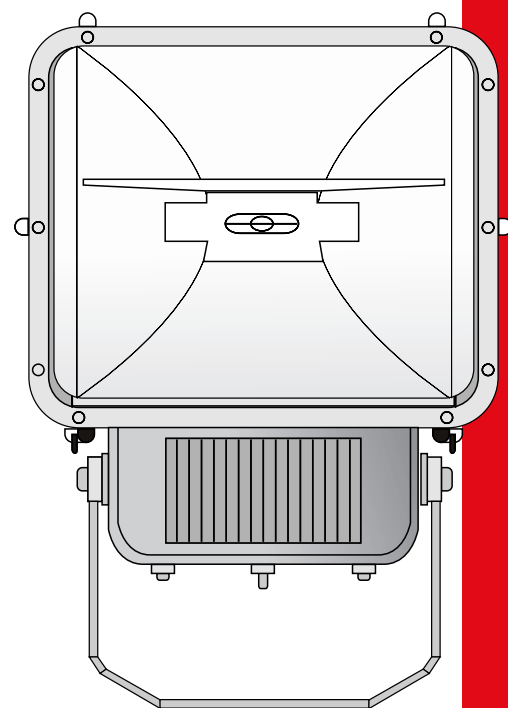

Model No.	Description	Voltage	Frequency	Lamp
FACP0032	LIGHTMASTER 1000W MH C/W Control Gear & Lamp (S)	220V-240V	50-60Hz	CAVO
FACP0033	LIGHTMASTER 1000W MH C/W Control Gear & Lamp (A)	220V-240V	50-60Hz	CAVO
FACP0034	LIGHTMASTER 1000W MH C/W Control Gear & Lamp (C)	220V-240V	50-60Hz	CAVO

(S) Symmetrical (A) Asymmetrical (C) Circular

ordering information