

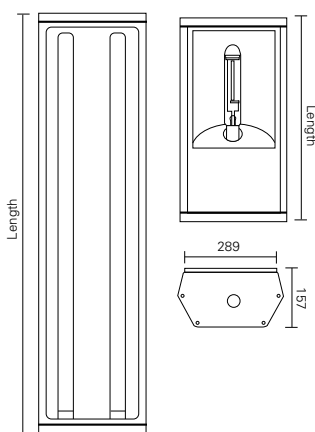

solar explorer



ADVANTAGES

- Architectural stylish appearance
- Fully aluminium and glass
- High performance
- Anti Corrosion and compact

APPLICATION

- Tunnel, by pass, under pass
- Roadway, wet location low bay use

FEATURES

- IP 65 construction, suitable for wet application.
- Toolless glass door opening method for easy and quick maintenance and re-lamping.
- 2.7mm thick extruded aluminium housing. Charcoal Filter.
- Passed 2g 3 dimensional 100,000 times vibration test.
- 99.5% high purity anodized reflector with symmetrical and asymmetrical optics with Anti Glare.
- 5mm thick vandal resistant glass door with a thermal resistant property over 250 C.
- Plug-in fuse. Stainless steel door screws and bracket studs.
- Installation kits are available on request.

CHARACTERISTICS

- Optical assembly : IP 65
- Ballast Compartment : IP 65
- Electrical Insulation : Class 1
- Voltage : 220V / 240V
- Wattage : 70W ~ 400W T8 18W / 36W / 58W
- Lamp type : HPSV, MH
- Approx. Net Weight : 6 ~ 9 kg

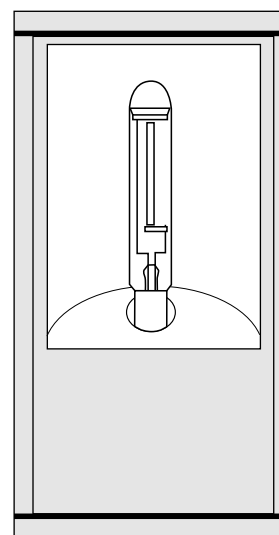

	Length
70W HPS	534.5
100W HPS	534.4
150W HPS	534.4
250W HPS	625.5
400W HPS	625.5
2x18L	714
2x36L	1314
2x36C	714
2x58L	1614

dimension (mm)

Model No.	Description	Voltage	Frequency	Lamp
GPCP0796	SOLAR EXPLORER 70W HPS C/W Gear & Lamp	220V-240V	50-60Hz	E27
GPCP0797	SOLAR EXPLORER 100W HPS C/W Gear & Lamp	220V-240V	50-60Hz	E40
GPCP0798	SOLAR EXPLORER 150W HPS C/W Gear & Lamp	220V-240V	50-60Hz	E40
GPCP0799	SOLAR EXPLORER 250W HPS C/W Gear & Lamp	220V-240V	50-60Hz	E40
GPCP0800	SOLAR EXPLORER 400W HPS C/W Gear & Lamp	220V-240V	50-60Hz	E40
GPCP0801	SOLAR EXPLORER 2x18L C/W Gear & Lamp	220V-240V	50-60Hz	G24
GPCP0802	SOLAR EXPLORER 2x36L C/W Gear & Lamp	220V-240V	50-60Hz	G24
GPCP0803	SOLAR EXPLORER 2x36C C/W Gear & Lamp	220V-240V	50-60Hz	G24
GPCP0804	SOLAR EXPLORER 2x58L C/W Gear & Lamp	220V-240V	50-60Hz	G24

ordering information