

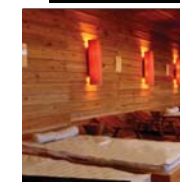

# amenity TUBAL

The Tubal is a compact wall illuminator with high emission LED technology. With minimal absorbed power (2.5W) and long life span, it allows attractive scenic effects at a very low cost without any maintenance.

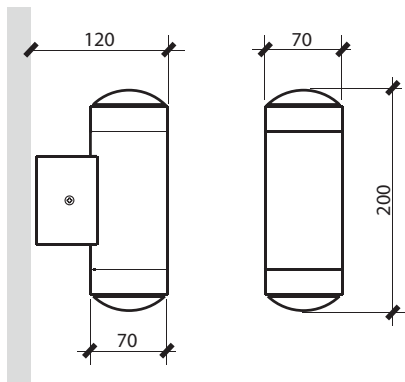

- 1
  - 2
  - 3
  - 4
  - 5
  - 6
  - 7
- APPLICATION COLOR CODE

tubal -     -    -

SOURCE	LED
LUMENS	100
LAMPLIFE	50,000 HRS
INPUT VOLTAGE	230VDC
OPERATING TEMP	-20°~60°
PROTECTION RATING	IP65

COLOR CODE	COLOR	BEAM ANGLE	POWER (WATTS)	PROJECTION DISTANCE	HOUSING DESCRIPTION	GEAR/CONTROLS	SIZE (MM)	SCHEMATIC DIAGRAM	
WARM	3000K	93°	2.5W	N.A.	ALUMINUM ALLOY BODY	BUILT-IN DRIVER + DMX DECODER (DMX CONTROLLABLE)	LENGTH	see Appendix	
COOL	5500K						70.0 Ø		
ORED	RED						WIDTH		
OGRN	GREEN						HEIGHT		
OBLU	BLUE								200.0
ORGB	RGB								

\*\*The company is constantly developing and improving its products. All descriptions, illustrations, and specifications mentioned present only general particulars and shall not form any part of any contract. The right is reserved to change specifications without prior notice.

\*\*FILL UP ORDERING REFERENCE ACCORDINGLY > example: NAME -     -    -